

BETRIEBSANLEITUNG

INSTRUCTION MANUAL

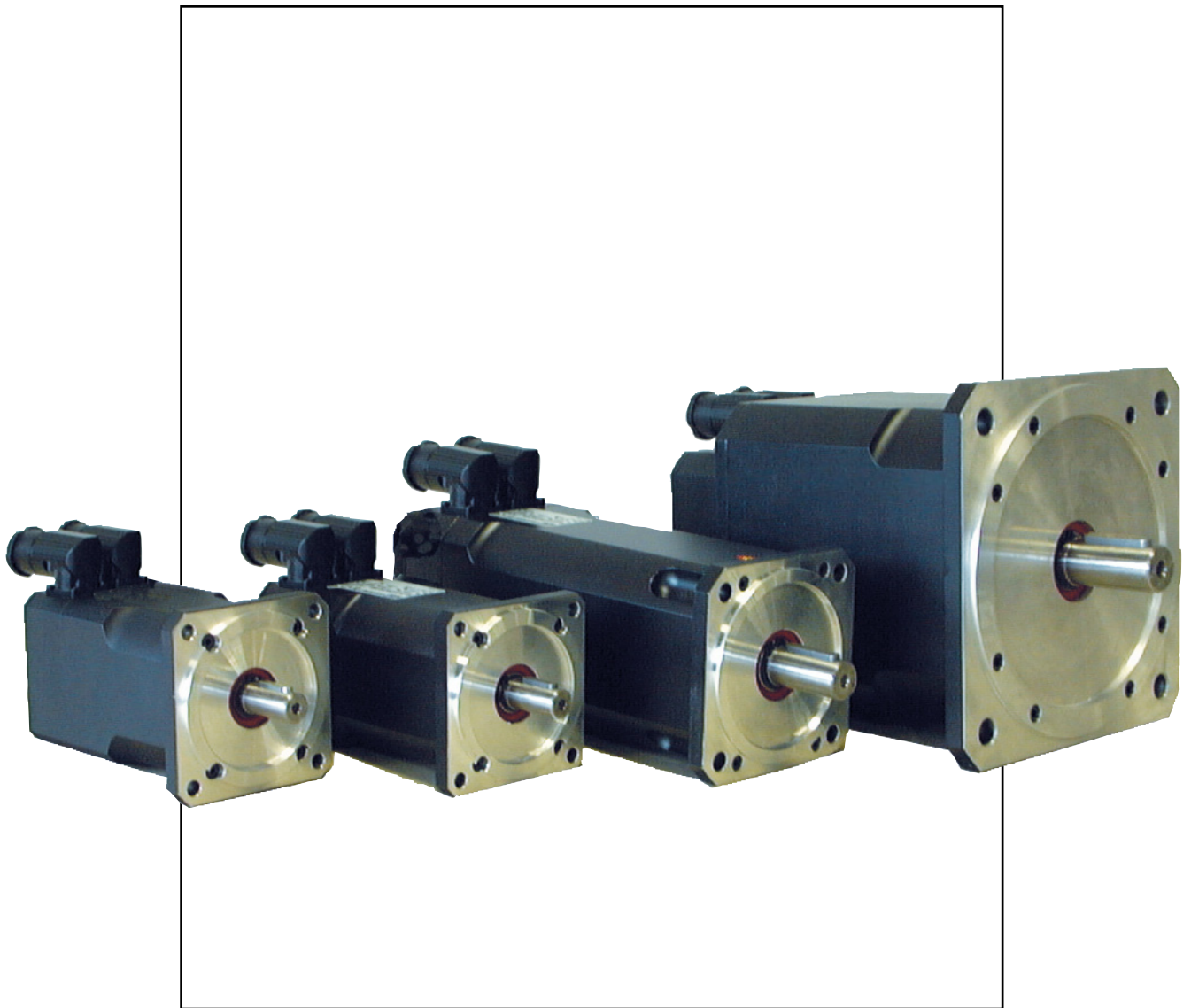

KEB Servomotore
KEB Servo Motors

Größe 11 . . . 84
Size 11 ... 84

Diese Betriebsanleitung beschreibt die Servomotoren 11...84 und muß jedem Anwender zugänglich gemacht werden. Vor jeglichen Arbeiten muß sich der Anwender mit dem Gerät vertraut machen. Den **Sicherheits- und Warnhinweisen** in dieser Anleitung und in der Beschreibung für den Servosteller sowie in weiterer Dokumentation ist für einen sicheren Betrieb unbedingt Folge zu leisten. Die in dieser Anleitung aufgeführten Sicherheits- und Warnhinweise erheben keinen Anspruch auf Vollständigkeit. Die KEB Antriebstechnik GmbH behält sich das Recht vor, Spezifikationen und technische Daten ohne vorherige Benachrichtigung zu ändern, bzw. anzupassen.

Die in dieser Betriebsanleitung verwendeten Pictogramme entsprechen folgender Bedeutung:



Gefahr / Warnung / Vorsicht

Wird verwendet, wenn Leben oder Gesundheit des Benutzers gefährdet sind oder erheblicher Sachschaden auftreten kann.



Achtung

Unbedingt beachten! Besondere Hinweise für den sicheren und störungsfreien Betrieb.



Information

Hilfestellung, Tip



**Nur qualifiziertes
Elektro-
Fachpersonal**

Alle Arbeiten zum Transport, Anschluß, zur Inbetriebnahme und Instandhaltung sind von qualifizierten, verantwortlichen

Fachpersonal auszuführen. Unsachgemäßes Verhalten kann schwere Personen- und Sachschäden verursachen. Ein sicherer und störungsfreier Betrieb ist nur bei Einhaltung der jeweils gültigen Vorschriften gemäß DIN VDE 0100, IEC1000, EN 60204-1, EN 55014, EN 50082-2 sowie einschlägiger örtlicher Bestimmungen gegeben.



Danger / Warning / Caution

Used when life or health of the user are exposed to danger or when the possibility of severe damage to the material exists.



Attention

Observe at all costs! Special instructions for a safe and trouble-free operation.



Information

Assistance, Tips



**Only qualified
Electro-
personnel**

The KEB COMBIVERT is operated with voltages that can cause a severe electric shock dangerous to life. Therefore the installation of the unit as well as of the available accessories is only permissible by qualified electro-personnel. A safe and trouble-free operation is only possible when the valid regulations according to DIN VDE 0100, IEC1000, EN 60204-1, EN 55014, EN 50082-2 as well as the relevant regulations for your area are observed.

Below the meaning of the pictograms used in this manual:

1.	Introduction.....	4
1.1	Intended Use	4
2.	Safety Instructions	4
3.	Transport and Storage	5
4.	Installation.....	5
4.1	Type of Protection	5
4.2	Ambient Temperature / Cooling	6
4.3	Output Components	6
5.	Electrical Connection.....	6
6.	Operation and Maintenance	6
7.	Part Code	7
8.	Project Design	8
8.1	Selection of the Servo Motor.....	8
8.2	Selection of the Servo Controller.....	8
9.	Start-up.....	9
9.1	Before Switching on.....	9
9.2	Switch on the Motor	9
10.	Technical Data	10
11.	Torque-Speed Characteristic.....	18
12.	Axial and Lateral Force	19
12.1	Shaft Load	19
12.3	Pretension Factor	20
12.2	Output Component.....	20
13.	Connection.....	20
13.1	Connector Assignments	20
14.	Options	23
14.1	Holding Brake	23

1. Introduction

1.1 Intended Use

The synchronous servo motors KEB COMBIVERT SM serve for the operation on digital servo controllers and are intended for industrial systems. They comply to the harmonized standards of the series VDE 0530/EN 60034. The use in hazardous areas is prohibited, unless it is explicitly permitted (observe additional instructions).

2. Safety Instructions



- All works on the installation are to be carried out in a **de-energized** state.
- In the case of synchronous motors with rotating rotor a high voltage is applied onto the motor connections.
- After mounting the motor check the faultless function of the brake (if available).
- Repairs may be carried out only by the manufacturer or repair places authorized by him. Unauthorized opening and improper tampering can lead to bodily injuries or damages to property.
- Before starting up motors with featherkey in the shaft end, the featherkey must be secured against flinging out, if this is not already prevented through output components like belt pulley, clutches or similar elements.
- The motors are not intended for direct connection to the three-phase system. They must be operated by a servo controller. A direct power connection can lead to the destruction of the motor.
- The motors can reach a surface temperature of more than 100°C. No temperature-sensitive parts may lay close to or be attached onto the motor. If necessary, protective measurements must be taken against touching.
- The optional built-in deadlock holding brake is only designed for a limited number of emergency stops. The use as a working brake is not permitted.
- For motors with plug connection and built-in brake you must install the varistor required for the brake wiring at commissioning.
- The thermistor fitted in the winding is to be connected and evaluated by a suitable wiring, for the protection of the motor against thermal overload in case of slow changes. **Attention:** The thermistor does not represent an all-around protection of the winding.

3. Transport and Storage

After final tests all motors leave the factory in perfect condition. On delivery check the motor for outside damages. If you should determine transport damages, then a notice of damage is to be issued in the presence of the carrier. If necessary, **stop the commissioning** of these motors.

Screwed-in ring bolts are designed for the weight of the motors, i.e. the attachment of additional loads is prohibited.

The storage is only permitted in **closed, dry, dust-free, ventilated** and **non-vibrating** environments. Before commissioning measure the insulation resistance. In case of values $\leq 1 \text{ k}\Omega$ per volt of rated voltage dry the winding (voltage of insulation resistance meter: 1000 V). After a longer storage (> 3 months) operate the motor at slow speed ($\leq 100 \text{ min}^{-1}$) in both directions, so that the lubrication can spread evenly in the bearings.

Damages that occur as a result of improper handling are not subject to our warranty.

4. Installation

When installing the motor make sure of even supporting surface, solid foot or flange mounting and exact alignment in case of direct coupling. Turn the motor shaft by **hand** and listen for abnormal slipping noises.

4.1 Type of Protection

The motors of the series 11...84 are designed in the type of protection IP65 (shaft gland IP64, optionally with shaft sealing ring IP65). The only exception is the built-on version "Shaft end upwards" (IM V3, IM V36), as here no liquid may remain in the D-side flange bearing end-shield.

By turning the flange sockets any outgoing cable direction can be adjusted (rotatable by 90° each). **Attention:** In the case of improper execution of the work the type of protection IP65 is no longer warranted.

If connector systems are used, then the type of protection IP65 is only achieved with correctly wired and firmly tightened mating connector.

4.2 Ambient Temperature / Cooling

Ambient temperature: -5°C . . . 40°C (194°F)

Site altitude: ≤ 1000 m above sea level

The motor must be mounted in such a manner that the ventilation is not obstructed, i.e. sufficient heat dissipation through convection and radiation must be ensured.

If the motor is equipped with a separate ventilator, it must be connected correctly. The exhaust air of neighbouring units may not be sucked in again directly. For three-phase separate ventilator connection the correct direction of rotation is to be checked (direction arrow towards ventilator housing).

4.3 Output Components

The rotor of the motor is dynamically balanced through a full featherkey in the shaft end according to DIN 6885 Sheet 1.

For motors with built-in radial sealing ring (option) only a reduced maximum speed is permissible according to the instruction manual.

For putting on or taking off output components (gear wheels, belt pulleys, clutches and similar parts) suitable devices are to be used. The bracing must be carried out on the D-side shaft end (Drive-End).

Attention: Servo motors are precision drive components, no shocks or impacts may arrive at the motor.

5. Electrical Connection

All work may be carried out only by qualified technical personnel on the motor at rest in de-energized status and secured against restarting. Verify the safe isolation from supply!

The connection must be carried out in such a way that a permanently safe, electrical connection is maintained. Pay attention to a safe protective conductor connection.

6. Operation and Maintenance

In case of changes as compared to the normal operation, e.g. increased temperature, noises, oscillations, find out the cause, if necessary, contact the manufacturer. In case of doubt switch off the motor!

The maintenance of the motor is limited to the cleaning of the motor surface.

The radial groove ball bearings of the motor are lubricated for life and are designed for nominal service life of 20.000 hours.

Motors with shaft sealing ring must be built in in connection with transmissions, that prevent a dry running of the shaft sealing ring. Otherwise it comes to squeaking noises, and an overheating of the motor because of the increased friction.

8. Project design

8.1 Selection of the Servo Motor

Calculate the following values before you selection the servo motor:

- Determine inertia (J_{App}) of the application without motor
- Calculate required peak torque (M_{Lmax}) of the application at the drive. The inertia of the motor (J_{Mot}) can be accepted here with 1/5 inertia (J_{App}) of the application.
- Determine the effective torque (M_{eff}) via the time.

Now the motor can be selected on the basis of the calculated values and the technical data of the following pages. The following selection features must be observed:

calculate		motor data
n_{max}	\leq	n_N
M_{Lmax}	\leq	M_{max}
M_{eff}	\leq	M_{dN}
$J_{App}/10$	\leq	J_{mot}

For examination or optimization it can be calculated again with the real motor data.

8.2 Selection of the Servo Controller

The selection of the servo controller occurs via the max. short time current limit and the output rated current.

$$\text{Max. short time current limit} = \frac{M_{Lmax} \cdot \text{Stall current (Id0)}}{\text{Stall torque (Md0)}}$$

$$\text{Output rated current} = \frac{\text{Effective torque} \cdot \text{Stall current (Id0)}}{\text{Stall torque (Md0)}}$$

9. Start-up

9.1 Before Switching on

Before initial operation and after major inspections, check the complete plant both from a mechanical and electrical point of view.

The procedure should include checks that:

- the installation and the operating conditions comply with the specified name-plate data,
- the motor is properly installed and aligned,
- the driving elements are properly adjusted (e.g. proper belt tension, coupling properly aligned and balanced),
- the motor is properly wired (power cables and leads of monitoring devices),
- The earthing and equipotential bonding have been made as specified in the applicable regulations,
- all fastening screws, connecting elements and electrical connections are properly tightened,
- the key is safed unless prevented otherwise by driving elements such as pulleys, couplings etc.
- the forced ventilation is correctly connected and in proper service condition,
- the direction of rotation of the fan motor corresponds with the direction arrow on the fan housing,
- the cooling air flow is not impaired (the hot outlet cooling air must not be drawn in by the fan!),
- the brakes, if provided, are inspected for proper functioning.

The following measures are recommended to be taken after installing or inspecting the motors:

9.2 Switch on the Motor

- Start the motor with no load.
- Check the mechanical running for any noise or vibrations on the bearings or end shields.
- If there is any abnormal noise or the motor runs unevenly, switch it off immediately and find out the cause.
- If the mechanical running improves immediately after the motor has been switched off, there is an electrical or magnetic cause. If this is not the case, there is a mechanical cause.
- If the mechanical running is smooth at no load, load the motor. Check the running smoothness, measure the voltage, current and power and record them. Measure and record these values also for the driven equipment, if possible.
- Monitor the temperatures of the bearings, windings etc. until they have stabilised and record the values (as far as this is possible with the available measuring equipment).

10. Technical Data

Servo motor		xx.S M.202-62yy	
Size (x)		11	12
Voltage and speed variant (y)		62yy	62yy
Stall torque M_{d0}	Nm	0,1	0,2
Current at stall torque I_{d0}	A	0,60	0,93
Nominal Rating			
Rated voltage U_N	V	230	230
Rated torque M_N	Nm	0,09	0,18
Rated current I_N	A	0,6	0,9
Rated speed n_N	min ⁻¹	6000	6000
Rated power P_N	W	60	110
Voltage constant k_F ¹⁾	V/1000min ⁻¹	14,8	18,4
Winding resistance R_{U-V}	Ohm	38,90	18,90
Winding inductance L_{U-V}	mH	6,5	4,5
Max. values			
max. torque M_{max}	Nm	0,40	0,80
max. current I_{max}	A	2,5	4,2
mechanical data ²⁾			
Inertia J_L	kgcm ²	0,06	0,08
Weight m	kg	0,8	0,8

¹⁾ Specify the peak value of motor EMK at 1000 rpm as line-to-line voltage.

²⁾ With resolver; without holding brake

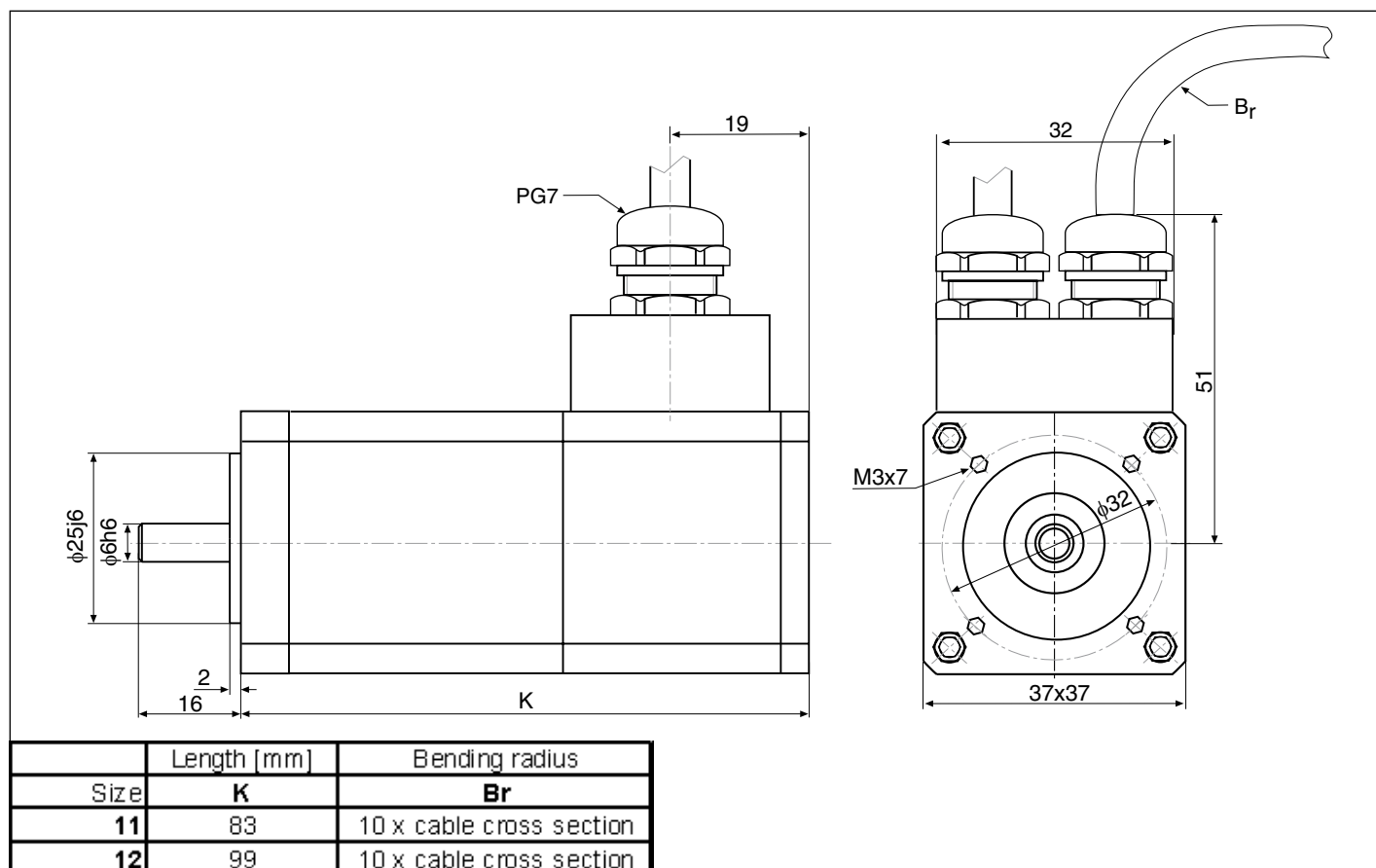

Servo motor		2x.S.M.200-yyyy							
Size (x)		21		22		23		24	
Voltage and speed variant (y)		4200	4400	4200	4400	4200	4400	4200	4400
Stall torque M_{d0}	Nm	0,2		0,4		0,6		0,8	
Current at stall torque I_{d0}	A	0,59	0,4	0,9	0,5	1,2	0,7	1,5	0,9
Nominal Rating									
Rated voltage U_N	V	230	400	230	400	230	400	230	400
Rated torque M_N	Nm	0,19		0,36		0,55		0,72	
Rated current I_N	A	0,6	0,5	0,9	0,5	1,1	0,7	1,5	0,9
Rated speed n_N	min ⁻¹	4500		4500		4500		4500	
Rated power P_N	W	90		170		260		340	
Voltage constant k_E ¹⁾	V/1000min ⁻¹	29	38,9	37,5	63,6	43,8	70,7	45,3	80,6
Winding resistance R_{u-v}	Ohm	53	99,5	26	77	19,4	50,8	14,6	46,5
Winding inductance L_{u-v}	mH	30,7	54	21,5	61,5	17,5	45,5	14,5	46,2
Max. values									
max. torque M_{max}	Nm	0,8		1,6		2,4		3,2	
max. current I_{max}	A	2,5	1,9	3,9	2,3	5,0	3,1	6,5	3,6
mechanical data ²⁾									
Inertia J_L	kgcm ²	0,06		0,08		0,11		0,13	
Weight m	kg	0,9		1,1		1,25		1,45	

¹⁾ Specify the peak value of motor EMK at 1000 rpm as line-to-line voltage.

²⁾ With resolver; without holding brake

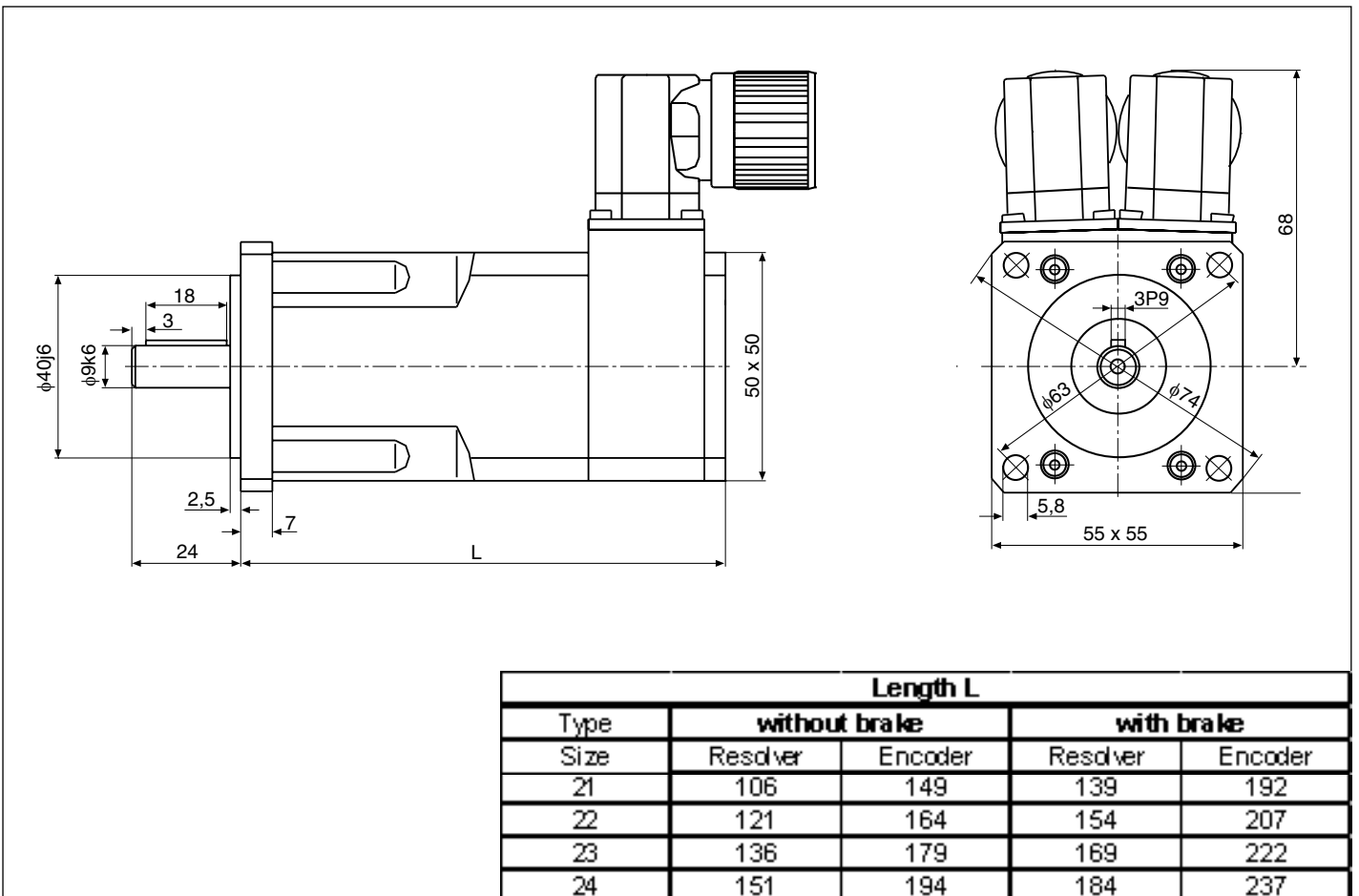

Technical Data

Servo motor		3x.S.M.200-yyyy							
Size (x)		31		32		35	33		34
Voltage and speed variant (y)		32yy	34yy	32yy	34yy	34yy	32yy	34yy	34yy
Stall torque M_{d0}	Nm	0,65		1,3		1,9	2,5		3
Current at stall torque I_{d0}	A	1,1	0,7	1,7	1,0	1,4	3,0	1,8	2,1
Nominal Rating									
Rated voltage U_N	V	230	400	230	400	400	230	400	400
Rated torque M_N	Nm	0,60		1,15		1,60	2,15		2,50
Rated current I_N	A	1,0	0,6	1,6	1,0	1,3	2,7	1,6	1,8
Rated speed n_N	min ⁻¹	3000		3000		3000	3000		3000
Rated power P_N	W	170		360		500	680		790
Voltage constant k_F ¹⁾	V/1000min ⁻¹	52,3	84,9	66,5	110,3	114,6	70,7	118,8	123,0
Winding resistance R_{U-V}	Ohm	28,5	75	12,7	34,5	20,9	5,4	15	11,6
Winding inductance L_{U-V}	mH	33,3	88	21,5	62	40,4	11,7	33,2	26,7
Max. values									
max. torque M_{max}	Nm	2,60		5,2		7,6	10,0		12,0
max. current I_{max}	A	4,6	2,8	7,2	4,3	6,1	13,0	7,7	9,0
mechanical data ²⁾									
Inertia J_L	kgcm ²	0,39		0,65		0,92	1,2		1,5
Weight m	kg	1,9		2,3		2,5	3,3		4

¹⁾ Specify the peak value of motor EMK at 1000 rpm as line-to-line voltage.

²⁾ With resolver; without holding brake

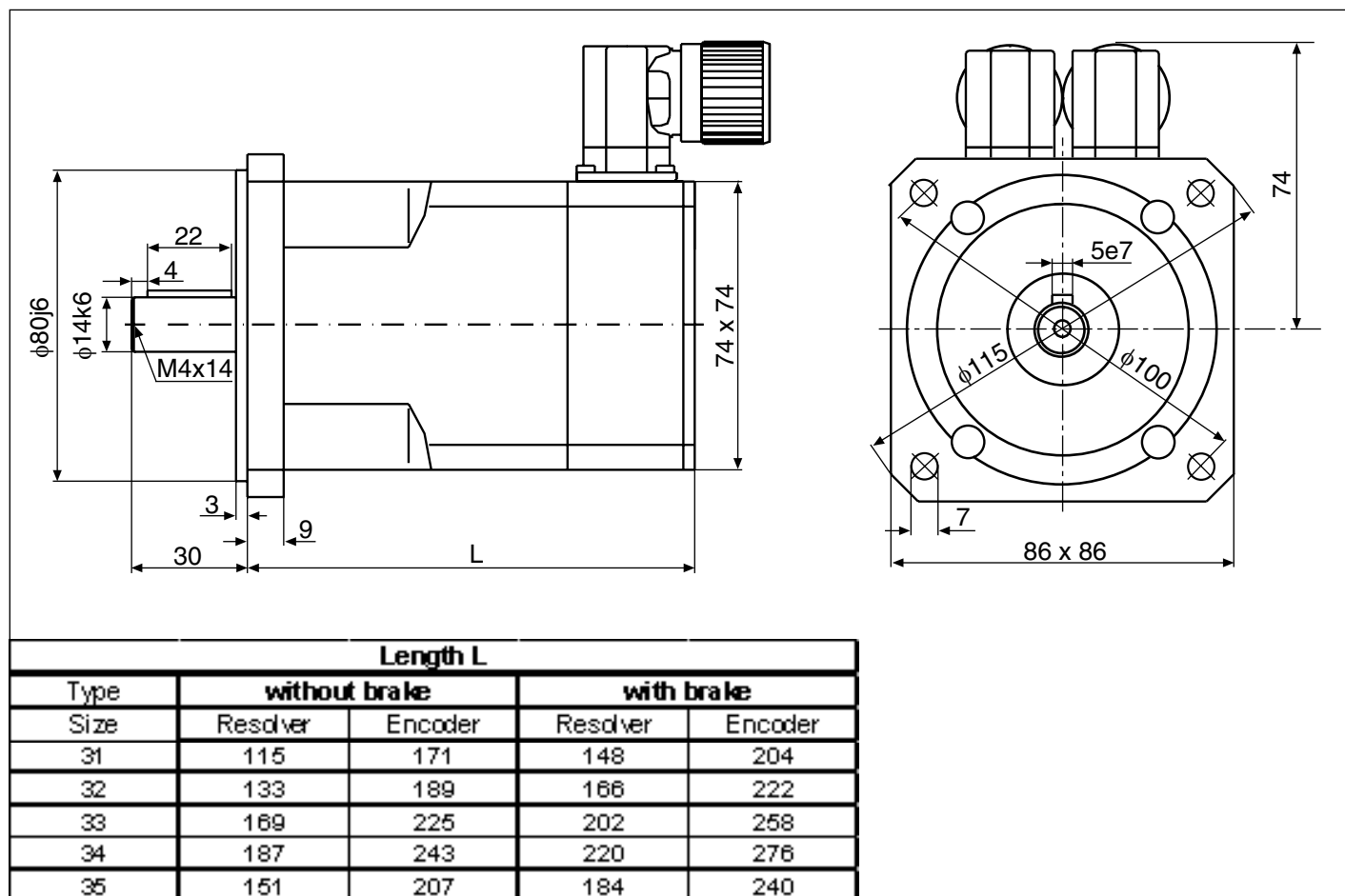

Servo motor		4x.S M.200-yyyy					
Size (x)	41		42		43	44	
	32yy	34yy	32yy	34yy	34yy	34yy	
Stall torque M_{d0}	Nm	2,6		5,3		7,5	9,5
Current at stall torque I_{d0}	A	3,1	1,9	6,5	4,1	4,8	6,4
Nominal Rating							
Rated voltage U_N	V	230	400	230	400	400	400
Rated torque M_N	Nm	2,30		4,60		6,40	8,50
Rated current I_N	A	3,0	1,9	5,9	3,8	4,4	6,0
Rated speed n_N	min ⁻¹	3000		3000		3000	3000
Rated power P_N	W	720		1440		2010	2670
Voltage constant k_F ¹⁾	V/1000min ⁻¹	70,7	116,0	70,0	110,3	132,9	127,3
Winding resistance R_{U-V}	Ohm	3,6	9,6	1,7	4,2	3	1,65
Winding inductance L_{U-V}	mH	15,9	41,5	9,8	24	19,2	11,7
Max. values							
max. torque M_{max}	Nm	10,40		21,2		30,0	38,0
max. current I_{max}	A	18,9	11,6	39,5	25,1	29,4	38,3
mechanical data ²⁾							
Inertia J_L	kgcm ²	1,9		2,65		4,15	6,05
Weight m	kg	4,5		5,7		7,6	8,7

1) Specify the peak value of motor EMK at 1000 rpm as line-to-line voltage.

2) With resolver; without holding brake

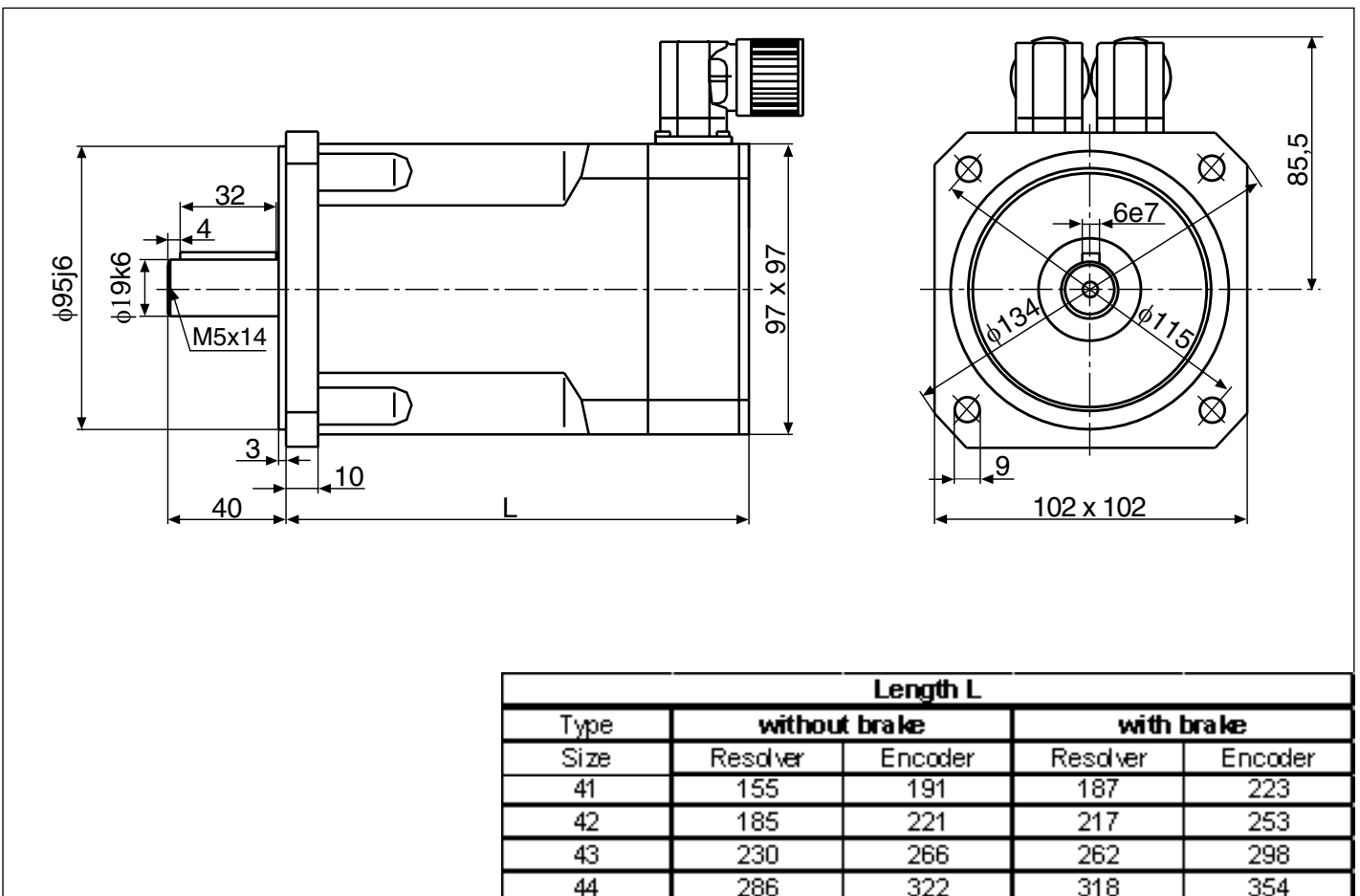

Technical Data

Servo motor	5x.SM.200-yyyy					
Size (x)	51	52	53	54	55	
Voltage and speed variant (y)	34yy	34yy	34yy	34yy	34yy	
Stall torque M_{d0}	Nm	6,6	10,5	13,5	17	22
Current at stall torque I_{d0}	A	4,7	7,2	9,2	10,6	12,8
Nominal Rating						
Rated voltage U_N	V	400	400	400	400	400
Rated torque M_N	Nm	5,6	8,5	10,7	14,5	17,5
Rated current I_N	A	4,2	6,2	7,7	9,3	10,5
Rated speed n_N	min ⁻¹	3000	3000	3000	3000	3000
Rated power P_N	W	1,76	2,67	3,36	4,55	5,5
Voltage constant k_F ¹⁾	V/1000min ⁻¹	120,2	124,5	125,9	137,2	147,1
Winding resistance R_{U-V}	Ohm	3,45	1,7	1,36	1,11	0,95
Winding inductance L_{U-V}	mH	20	12,5	10,5	11	10,5
Max. values						
max. torque M_{max}	Nm	19,8	31,5	40,5	51,0	66,0
max. current I_{max}	A	23,4	35,9	45,7	52,8	63,7
mechanical data ²⁾						
Inertia J_L	kgcm ²	6,05	9,3	10,6	9,5	11,7
Weight m	kg	8	9,8	11,2	14	17

¹⁾ Specify the peak value of motor EMK at 1000 rpm as line-to-line voltage.

²⁾ With resolver; without holding brake

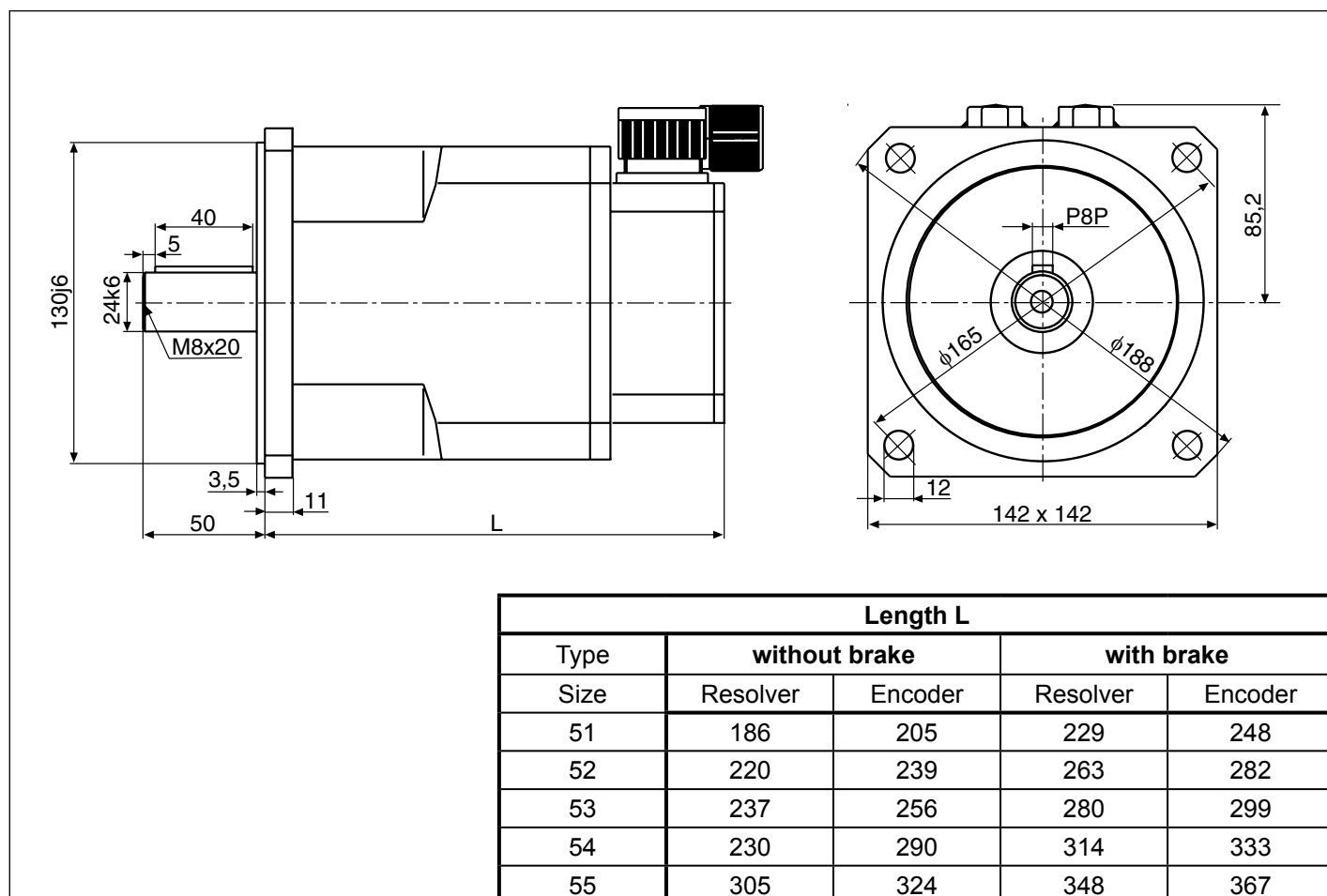

Servo motor		6x.S M.200-yyyy			
Size (x)		61	62	63	64
Voltage and speed variant (y)		34yy	34yy	34yy	34yy
Stall torque M_{d0}	Nm	13,5	19	22	29
Current at stall torque I_{d0}	A	10,6	13,4	15,0	17,2
Nominal Rating					
Rated voltage U_N	V	400	400	400	400
Rated torque M_N	Nm	10	14	16	24
Rated current I_N	A	8,4	10,8	11,8	14,7
Rated speed n_N	min ⁻¹	3000	3000	3000	3000
Rated power P_N	W	3,14	4,4	5,03	7,54
Voltage constant k_F ¹⁾	V/1000min ⁻¹	108,9	121,6	125,9	144,2
Winding resistance R_{U-V}	Ohm	1,5	0,88	0,74	0,31
Winding inductance L_{U-V}	mH	14,8	10,6	9,2	5,6
Max. values					
max. torque M_{max}	Nm	40,5	57,0	66,0	101,5
max. current I_{max}	A	53,0	66,8	74,8	84,0
mechanical data ²⁾					
Inertia J_I	kgcm ²	10,8	15,7	18,8	29,5
Weight m	kg	11,9	18,3	21,5	27

¹⁾ Specify the peak value of motor EMK at 1000 rpm as line-to-line voltage.

²⁾ With resolver; without holding brake

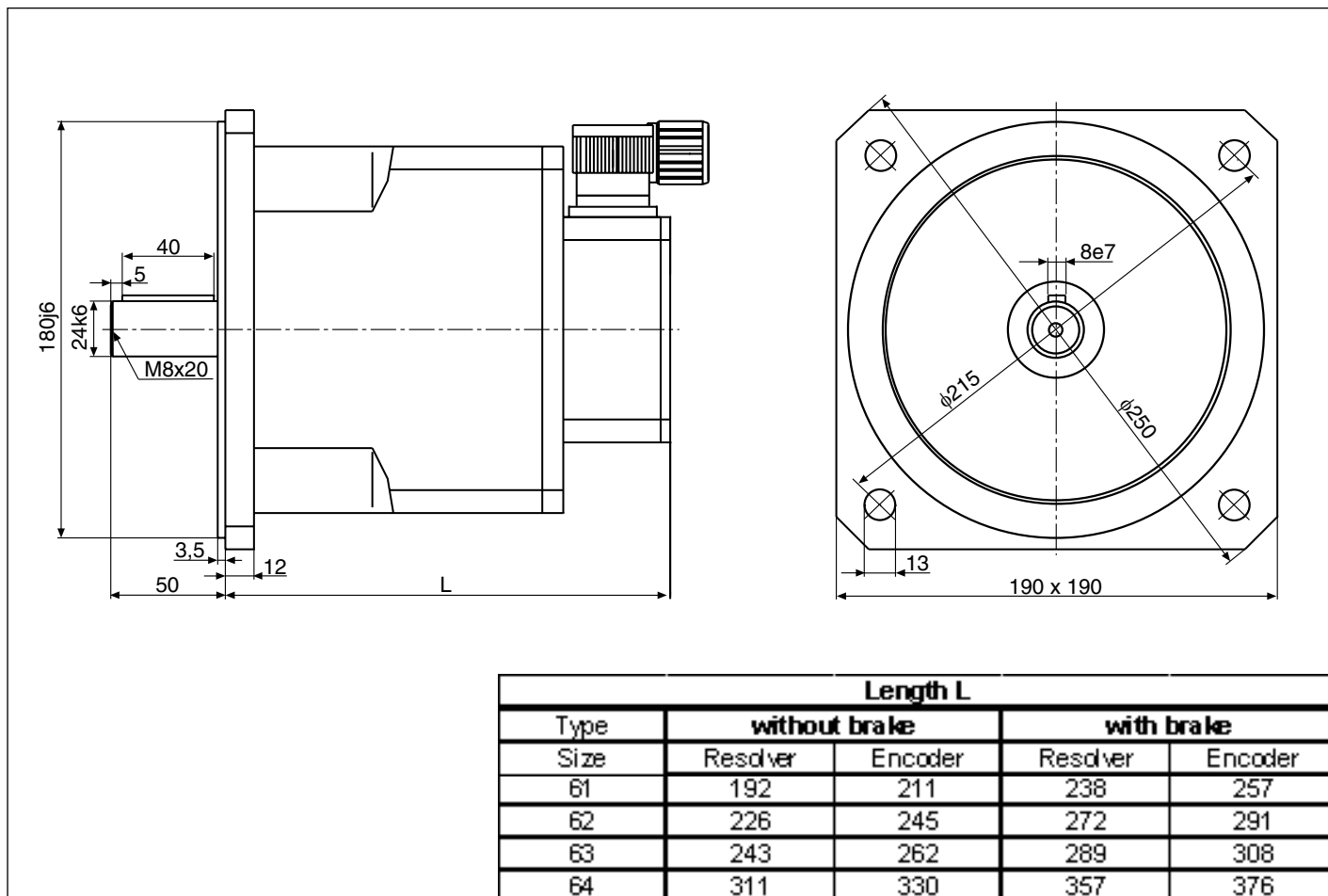

Technical Data

Servo motor		7x.S M.200-yyyy		
Size (x)		71	72	73
Voltage and speed variant (y)		34yy	34yy	34yy
Stall torque M_{d0}	Nm	26	32	40
Current at stall torque I_{d0}	A	16,9	21,3	23,9
Nominal Rating				
Rated voltage U_N	V	400	400	400
Rated torque M_N	Nm	20	23	26
Rated current I_N	A	14,1	16,8	17,3
Rated speed n_N	min ⁻¹	3000	3000	3000
Rated power P_N	W	6,28	7,22	8,17
Voltage constant k_F ¹⁾	V/1000min ⁻¹	131,5	128,7	142,8
Winding resistance R_{U-V}	Ohm	0,46	0,3	0,27
Winding inductance L_{U-V}	mH	5,1	3,7	3,4
Max. values				
max. torque M_{max}	Nm	78,0	96,0	120,0
max. current I_{max}	A	65,9	82,9	93,0
mechanical data ²⁾				
Inertia J_L	kgcm ²	67	81	101
Weight m	kg	28	32,5	40

¹⁾ Specify the peak value of motor EMK at 1000 rpm as line-to-line voltage.

²⁾ With resolver; without holding brake

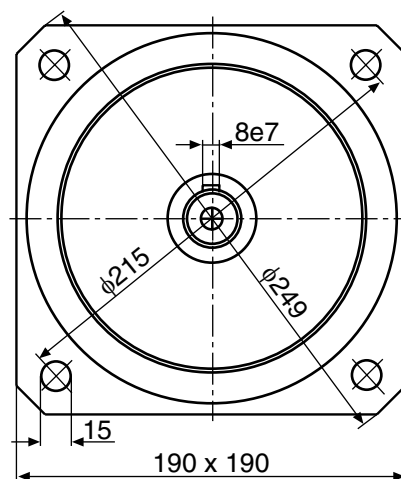
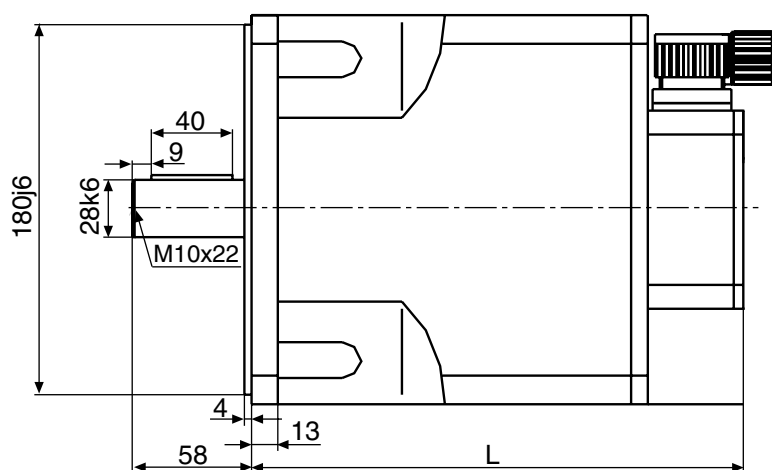

Type	Length L			
	without brake		with brake	
Size	Resolver	Encoder	Resolver	Encoder
71	240	259	284	303
72	263	282	307	326
73	298	317	342	361

Servo motor		8x.S M.200-yyyy			
Size (x)		81	82	83	84
Voltage and speed variant (y)		34yy	34yy	24yy	24yy
Stall torque M_{d0}	Nm	40	68	93	115
Current at stall torque I_{d0}	A	21,8	35,8	33,1	42,1
Nominal Rating					
Rated voltage U_N	V	400	400	400	400
Rated torque M_N	Nm	30	50	70	85
Rated current I_N	A	17,8	27,8	26,0	32,4
Rated speed n_N	min ⁻¹	3000	3000	2000	2000
Rated power P_N	W	9,42	15,71	14,66	17,8
Voltage constant k_F ¹⁾	V/1000min ⁻¹	157,0	162,6	240,4	233,3
Winding resistance R_{U-V}	Ohm	0,25	0,13	0,15	0,11
Winding inductance L_{U-V}	mH	5,7	3,3	4,8	3,4
Max. values					
max. torque M_{max}	Nm	120,0	204,0	279,0	345,0
max. current I_{max}	A	85,0	139,4	129,0	164,3
mechanical data ²⁾					
Inertia J_I	kgcm ²	76,1	113,6	152,6	190,1
Weight m	kg	43	54	74	93

1) Specify the peak value of motor EMK at 1000 rpm as line-to-line voltage.

2) With resolver; without holding brake

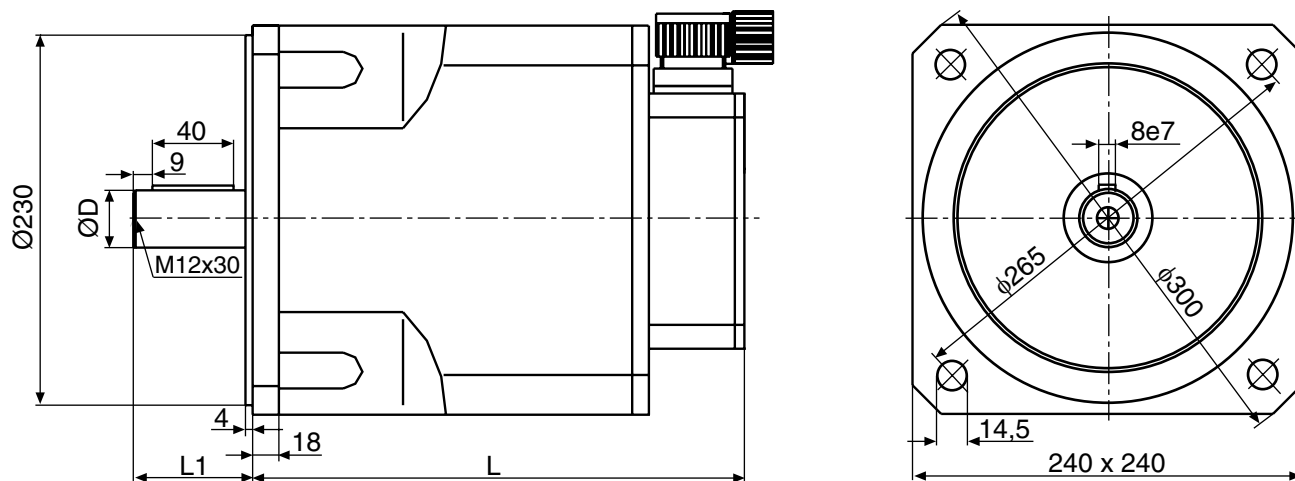

Type	Length L				Shaft	
	without brake		with brake		Ø D	L1
Size	Resolver	Encoder	Resolver	Encoder		
81	311	322	379	390	38	80
82	379	390	447	458	38	80
83	447	458	515	526	42	110
84	515	526	583	594	42	110

11. Torque-Speed Characteristic

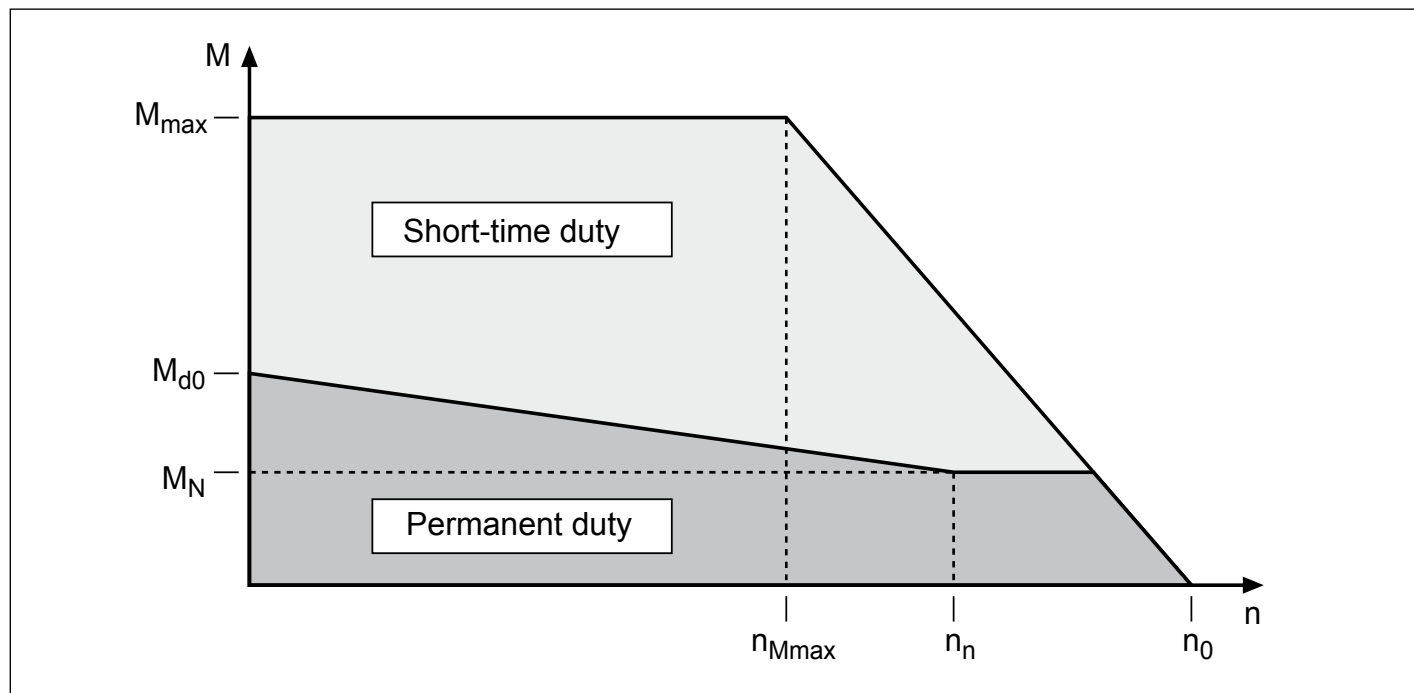

KEB Part.No.	M_{max}	M_{d0} [Nm]	M_N	n_n	n_{Mmax} [rpm]	n_0
11.SM.20B-62N0	0,4	0,1	0,09	6000	12650	21900
12.SM.20B-62N0	0,8	0,2	0,18	6000	10550	17650
21.SM.200-4200	0,8	0,2	0,19	4500	4250	11200
21.SM.2xx-44xx	0,8	0,2	0,19	4500	6850	14500
22.SM.200-4200	1,6	0,4	0,36	4500	3850	8650
22.SM.2xx-44xx	1,6	0,4	0,36	4500	4000	8850
23.SM.200-4200	2,4	0,6	0,55	4500	3300	7400
23.SM.2xx-44xx	2,4	0,6	0,55	4500	3700	8000
24.SM.200-4200	3,2	0,8	0,72	4500	3050	7150
24.SM.2xx-44xx	3,2	0,8	0,72	4500	3000	7000
31.SM.200-3200	2,6	0,65	0,60	3000	2150	6200
31.SM.2xx-34xx	2,6	0,65	0,60	3000	2500	6650
32.SM.200-3200	5,2	1,3	1,15	3000	2000	4850
32.SM.2xx-34xx	5,2	1,3	1,15	3000	2150	5100
33.SM.200-3200	10	2,5	2,15	3000	2250	4600
33.SM.2xx-34xx	10	2,5	2,15	3000	2400	4750
34.SM.2xx-34xx	12	3	2,5	3000	2600	4550
35.SM.2xx-34xx	7,6	1,9	1,6	3000	2300	4900
41.SM.200-3200	10,4	2,6	2,3	3000	1850	4600
41.SM.2xx-34xx	10,4	2,6	2,3	3000	2200	4850

KEB Part.No.	M_{max}	M_{d0} [Nm]	M_N	n_n	n_{Mmax} [rpm]	n_0
42.SM.200-3200	21,2	5,3	4,6	3000	2100	4600
42.SM.2xx-34xx	21,2	5,3	4,6	3000	1700	5100
43.SM.2xx-34xx	30	7,5	6,4	3000	1850	4250
44.SM.2xx-34xx	38	9,5	8,5	3000	2300	4400
51.SM.2xx-34xx	19,8	6,6	5,6	3000	1950	4700
52.SM.2xx-34xx	31,5	10,5	8,5	3000	2250	4500
53.SM.2xx-34xx	40,5	13,5	10,7	3000	2000	4450
54.SM.2xx-34xx	51	17	14,5	3000	1800	4100
55.SM.2xx-34xx	66	22	17,5	3000	1450	3800
61.SM.2xx-34xx	40,5	13,5	10	3000	1550	5150
62.SM.2xx-34xx	57	19	14	3000	1700	4650
63.SM.2xx-34xx	66	22	16	3000	1900	4450
64.SM.2xx-34xx	101,5	29	24	3000	1950	3900
71.SM.2xx-34xx	78	26	20	3000	2250	4300
72.SM.2xx-34xx	96	32	23	3000	2400	4350
73.SM.2xx-34xx	120	40	26	3000	2250	3950
81.SM.2xx-34xx	120	40	30	3000	1400	3600
82.SM.2xx-34xx	204	68	50	3000	1650	3450
83.SM.2xx-24xx	279	93	70	2000	1100	2350
84.SM.2xx-24xx	345	115	85	2000	1250	2400

12. Axial and Lateral Force

Information for a lifetime of 20000 hours. F_R and F_A shall not occur simultaneously.

The values mentioned below can be exceeded about 10% with a lateral force F_R in the center line of shaft

Motor	Radial force F_R [N] at speed n [rpm]				Axial force F_A [N] at speed n [rpm]			
	2000	3000	4000	6000	2000	3000	4000	6000
1x	120	85	75	60	40	28	25	20
2x	200	115	85	50	67	38	28	17
3x	400	350	300	280	133	117	100	93
4x	700	580	520	500	233	193	173	167
5x	800	640	600	590	267	213	200	197
6x	850	680	670	650	283	227	223	217
7x	1100	780	740	720	367	260	247	240
8x	1800	1450	1400	1300	600	483	467	433

F_R : permissible lateral force at shaft end

F_{Rm} : permissible lateral force in the center line of shaft ($=F_R + 10\%$)

F_A : permissible Axial force

12.1 Shaft Load

The endurance strength of the shaft and the service life on the bearings determine the permissible lateral force F_{Rm} on the D(rive-End)-side shaft end.

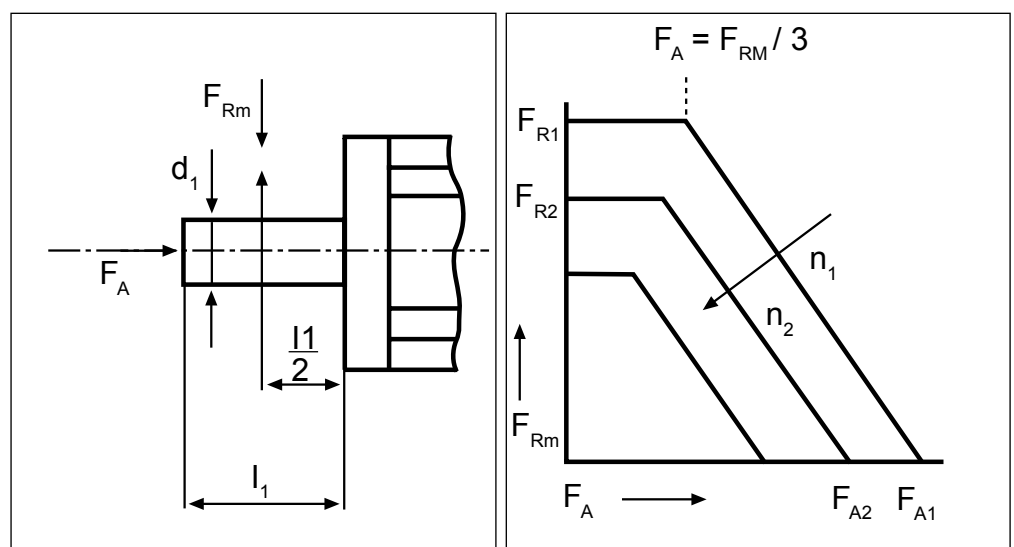

12.2 Output Component

The smallest possible effective circular diameter of the output component can be computed as follows:

$$D_w = \frac{k * 2 * M_b}{F_{Rm}}$$

D_w : effective circular diameter of the output components

K : pretension factor

F_{Rm} : permissible lateral force

M_b : acceleration torque of the drive

12.3 Pretension Factor

Empirical values for the pretension factor k :

ca. $k = 1,5$ for pinion

ca. $k = 1,2$ to $2,0$ for toothed belt

ca. $k = 2,2$ to $3,0$ for flat belt

For dynamic processes like braking and accelerating, the permissible lateral force F_R is not to be exceeded in order to avoid a mechanical destruction of the motor.

13. Connection

13.1 Connector Assignments

Connection power connector size 1

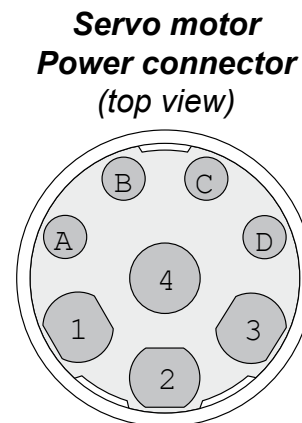

Connector PIN	Designation	Cable Core
1	U	1
4	V	2
3	W	3
2	PE	green-yellow
A	Brake +	5
B	Brake -	6
C	PTC-Contact (T1)	7
D	PTC-Contact (T2)	8

Connection power connector size 1,5

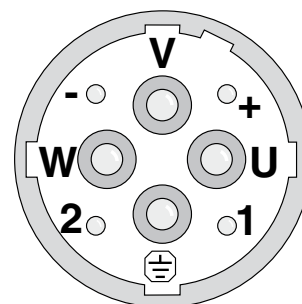

Connector PIN	Designation	Cable Core
U	U	1
V	V	2
W	W	3
PE	PE	green-yellow
+	Brake +	5
-	Brake -	6
1	PTC-Contact (T1)	7
2	PTC-Contact (T2)	8

Power connection
Motor size 11 and 12

Designation	Cable Core
U	1
V	2
W	3
PE	green-yellow
Brake +	5
Brake -	6

PTC-connection (230 V / 400 V - Class)		1...3 PTC-detectors (series connection)
max. cold resistance of PTC-detector cha	[Ω]	400
Error tripping range	[Ω]	≥ 1650
Error reset range	[Ω]	≤ 500

Connection resolver
motor size 11 and 12

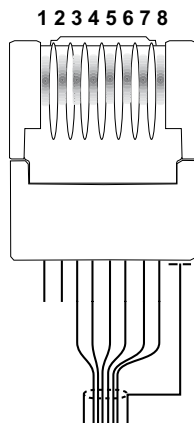

RJ45 PIN	Designation	Cable Color
1	-	-
2	-	-
3	SIN_REF	green
4	SIN	blue
5	SIN_LO	red
6	SIN_REF_LO	yellow
7	COS	gray
8	COS_LO	pink

Connection resolver

**Servo motor
Resolver connector
(top view)**

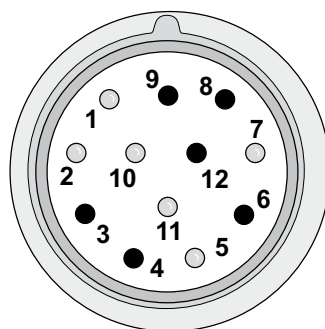

Connector PIN	Designation	Cable Color
1	SIN_LO	red
2	COS_LO	pink
5	SIN_REF_LO	yellow
7	SIN_REF	green
10	SIN	blue
11	COS	gray

Contacts 3, 4, 6, 8, 9 and 12 are not assigned.

Terminal Assignment

Connection SIN/COS
Encoder

**Servo motor
SIN/COS-encoder connector
(top view)**

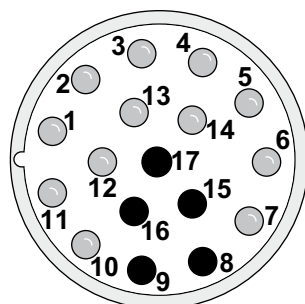

Connector PIN	Designation	Cable Color
1	A (+)	green
2	A (-)	yellow
3	R (+)	gray
4	D (-)	purple
5	C (+)	white
6	C (-)	brown
7	GND	white/green
10	+5 V	gray / pink
11	B (+)	blue
12	B (-)	red
13	R (-)	pink
14	D (+)	black

Contacts 8, 9, 15, 16 and 17 are not assigned.

Connection EnDat
Encoder

**Servo motor
EnDat-encoder connector
(top view)**

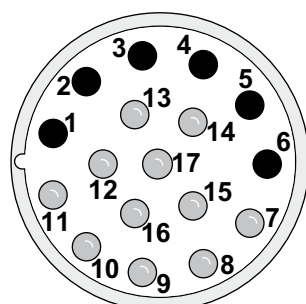

Connector PIN	Designation	Cable Color
7	+5V	white
8	Clock (+)	black
9	Clock (-)	purple
10	COM	brown
12	B (+)	blue
13	B (-)	red
14	Data (+)	gray
15	A (+)	green
16	A (-)	yellow
17	Data (-)	pink

Contacts 1...6 are not assigned.

Connection Hiperface
Encoder

**Servo motor
Hiperface-encoder connector
(top view)**

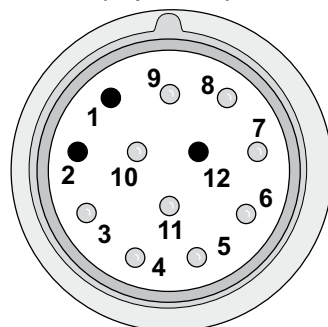

Connector PIN	Designation	Cable Color
4	REF_SIN (-)	red
5	REF_COS (-)	yellow
6	Data (+)	gray
7	Data (-)	pink
8	SIN (+)	blue
9	COS (+)	green
10	+7,5V	brown
11	COM	white

Contacts 1, 2 and 12 are not assigned.

Motor cable and encoder cable The UL tested motor and encoder cables can be acquired ready-made in different lengths by KEB. The cables are dragable and appropriated for a continuous bending radius of 120 mm.

14. Options

14.1 Holding Brake

Motor typ	1x.S.M.200-yyyy	2x.S.M.200-yyyy	3x.S.M.200-yyyy	4x.S.M.200-yyyy
Holding torque [Nm]	0,4	2	4,5	9
Moment of inertia [kgcm ²]	0,032	0,068	0,18	0,54
max. Speed [min ⁻¹]	10.000	10.000	10.000	10.000
Mass [kg]	0,14	0,18	0,35	0,52
Rated voltage [V]	24 (+6%, -10%)			
Rated current [A]	0,33	0,46	0,5	0,75
Release time t2 [ms]	10	25	35	40
Engaging delay t11 [ms]	2	2	2	2
Engaging time t1 [ms]	6	6	7	7
Power [W]	8	11	12	18
Typ	01.P1.320	03.P1.320	05.P1.320	06.P1.320

Motor typ	5x.S.M.200-yyyy	6x.S.M.200-yyyy	7x.S.M.200-yyyy	8x.S.M.200-yyyy
Holding torque [Nm]	18	36	36	145
Moment of inertia [kgcm ²]	1,66	5,9	5,9	39
max. Speed [min ⁻¹]	10.000	10.000	10.000	8.000
Mass [kg]	1	1,95	1,95	5,35
Rated voltage [V]	24 (+6%, -10%)			
Rated current [A]	0,83	1,09	1,09	2,1
Release time t2 [ms]	50	90	90	190
Engaging delay t11 [ms]	3	3	3	12
Engaging time t1 [ms]	30	22	22	65
Power [W]	24	26	26	50
Typ	07.P1.320	08.P1.320	08.P1.320	10.P1.320

The indicated switching times are reached with adjusted nominal air gap (Xmin). There are average values, whose leakage is dependent on the power supply and the coil temperature. The marking of the switching times corresponds to DIN VDE 580.

The motors of the series 11...84 with built-in holding brake are not to be loaded with axial forces, as this causes a change of the working airgap of the holding brake thereby making the brake inoperative.



KEB Automation KG
Südstraße 38 • D-32683 Barntrup
fon: +49 5263 401-0 • fax: +49 5263 401-116
net: www.keb.de • mail: info@keb.de

KEB Antriebstechnik GmbH & Co. KG
Wildbacher Str. 5 • D-08289 Schneeberg
fon: +49 3772 67-0 • fax: +49 3772 67-281
mail: info@keb-combidrive.de

KEB Antriebstechnik Austria GmbH
Ritzstraße 8 • A-4614 Marchtrenk
fon: +43 7243 53586-0 • fax: +43 7243 53586-21
net: www.keb.at • mail: info@keb.at

KEB Antriebstechnik
Herenveld 2 • B-9500 Geraadsbergen
fon: +32 5443 7860 • fax: +32 5443 7898
mail: vb.belgien@keb.de

KEB Power Transmission Technology (Shanghai) Co.,Ltd.
No. 435 QianPu Road, Songjiang East Industrial Zone,
CHN-201611 Shanghai, P.R. China
fon: +86 21 37746688 • fax: +86 21 37746600
net: www.keb.cn • mail: info@keb.cn

KEB Antriebstechnik Austria GmbH
Organizační složka
K. Weise 1675/5 • CZ-370 04 České Budějovice
fon: +420 387 699 111 • fax: +420 387 699 119
net: www.keb.cz • mail: info.keb@seznam.cz

KEB España
C/ Mitjer, Nave 8 - Pol. Ind. LA MASIA
E-08798 Sant Cugat Sesgarrigues (Barcelona)
fon: +34 93 897 0268 • fax: +34 93 899 2035
mail: vb.espana@keb.de

Société Française KEB
Z.I. de la Croix St. Nicolas • 14, rue Gustave Eiffel
F-94510 LA QUEUE EN BRIE
fon: +33 1 49620101 • fax: +33 1 45767495
net: www.keb.fr • mail: info@keb.fr

KEB (UK) Ltd.
6 Chieftain Business Park, Morris Close
Park Farm, Wellingborough GB-Northants, NN8 6 XF
fon: +44 1933 402220 • fax: +44 1933 400724
net: www.keb-uk.co.uk • mail: info@keb-uk.co.uk

KEB Italia S.r.l.
Via Newton, 2 • I-20019 Settimo Milanese (Milano)
fon: +39 02 33535311 • fax: +39 02 33500790
net: www.keb.it • mail: kebitalia@keb.it

KEB Japan Ltd.
15-16, 2-Chome, Takawawa Minato-ku
J-Tokyo 108-0074
fon: +81 33 445-8515 • fax: +81 33 445-8215
mail: info@keb.jp

KEB Korea Seoul
Room 1709, 415 Missy 2000
725 Su Seo Dong, Gang Nam Gu
ROK-135-757 Seoul/South Korea
fon: +82 2 6253 6771 • fax: +82 2 6253 6770
mail: vb.korea@keb.de

KEB RUS Ltd.
Krasnokazarmeny proezd 1,
Metrostation „Aviamotornay“
RUS-111050 Moscow / Russia
fon: +007 445 695 3912 • fax: +007 495 645 3913
mail: info@keb.ru

KEB Sverige
Box 265 (Bergavägen 19)
S-43093 Hälsö
fon: +46 31 961520 • fax: +46 31 961124
mail: vb.schweden@keb.de

KEB America, Inc.
5100 Valley Industrial Blvd. South
USA-Shakopee, MN 55379
fon: +1 952 224-1400 • fax: +1 952 224-1499
net: www.kebamerica.com • mail: info@kebamerica.com